



# V18

## Sit-Down Counterbalanced



### CAPACITY

V-18 1588kg at 600mm load center

### PERFORMANCE

48 volt lithium batteries with 360 Ah capacity ZAPI AC lift and travel control.

### TRAVEL

14km/h empty  
13km/h loaded

### LIFT

Up to 0.4m/s empty  
Up to 0.3m/s loaded

### LOWERING

Up to 0.4 m/s empty  
Up to 0.4m/s loaded

### TIRES

FRONT DRIVE X 2  
18X7-8 solid pneumatic  
DUAL STEER TIRE  
15X4.5-8 solid pneumatic

### OPERATOR COMPARTMENT

Ergonomic roomy cab, wide view mast, hydrostatic power steering with spinner knob, adjustable steering column and adjustable suspension seat ensures comfortable working position. Hydraulic controls: lift/lower, tilt, and load side-shift within easy reach of operator.

Large "wide view" reversing mirror increases operation efficiency. Side hand rail aids operator comfort in reverse driving position.

### HYDRAULICS

Powerful AC hydraulic lift motor provides smooth high torque lifting and lowering. Hydraulic lift and drive components are sealed against dirt and water protecting them from contamination.

### ELECTRICAL

AC technology fitted to heavy-duty applications. Electrical current is optimized and AC motors are brushless, which minimizes servicing. "neutral braking" eliminates truck roll-back and allow higher travel speeds. Diagnostic display with thirty performance travel and lift parameters can be adjusted to suit all types of loads, working condition's area and operator driving skill.

### DRIVE UNIT AND BRAKES

Dual drive motors offer great maneuverability. The incorporation of ZF® developed components, including finely engineered helical gears, assured low noise, high quality and a long service life with low maintenance.

The "V" series three-wheel truck has three independent braking systems: regenerative "neutral braking", hydraulic wet disc braking, and toggle-type parking brake.

### FRAME AND MAST

High stability chassis with long wheel-base, wide tires and low center of gravity. "See Thru" integral side-shift with load back rest (LBR). Wide view mast, low scuttle and high seating position gives the operator an excellent view, reducing load damage and accidents. Fully enclosed chassis weldment house the dual drive motors.

### SERVICEABILITY

The state of-the-art controller can be easily accessed at waist height, reducing service time. Uncomplicated removable side battery compartment allows battery maintenance.

### STANDARD EQUIPMENT

- Headlights and Brake Lights
- Yellow Flashing Light
- Solid Pneumatic Tires
- Dual Steer Tire
- Integral Side-Shift
- Ergonomic Operators Compartment



#### V-18 RATED CAPACITY

1588kg to 3000mm @600mm LC  
1124kg to 4800 mm @600mm LC

Gradeability: Loaded 10.5%

Unloaded 14.5%

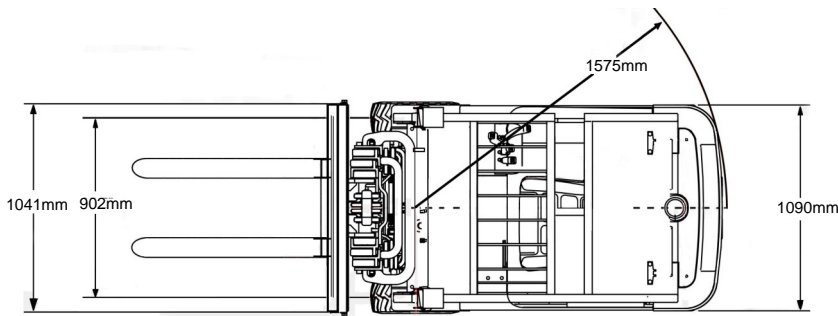
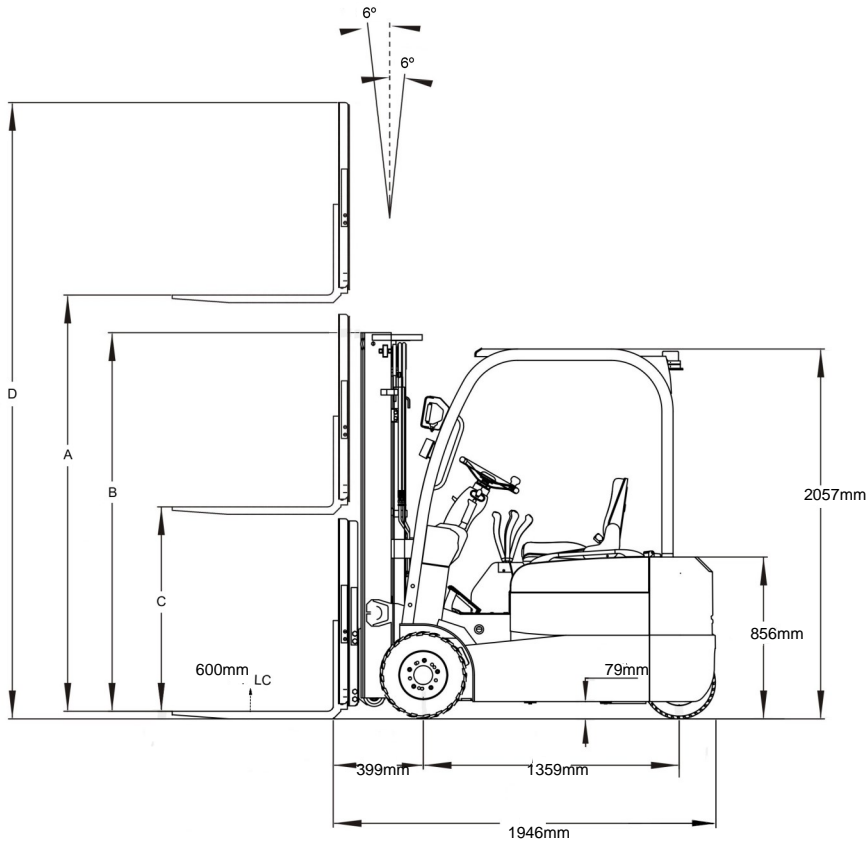

Model #	Mast	Lift Height	Col Height	Free Lift		Extended Height		<sup>3</sup> Weight (kg)
				Without Backrest	With Backrest	Without Backrest	With Backrest	
		A	B	C		D		

#### 1588kg Capacity @ 600mm Load Center

V18-177	TriMast	4496	2057	1473	991	5029	5563	3313
V18-188	TriMast	4775	2159	1575	1092	5334	5867	3368

<sup>3</sup>Estimated shipping weight without battery